



PRODUCT SPECIFICATION

EG8200Lite



前言 PREFACE

Intended Use

This product (EG Series Edge Computing Gateway) is only for use as specified in relevant technical documents. Proper transport, storage, assembly, installation, commissioning, operation, and maintenance are required for safe, reliable operation. Ensure permissible environmental conditions (e.g., temperature, humidity, supply voltage). Observe all notices in this specification and related documents.

Qualified Personnel

Only qualified personnel may operate the products/systems described. Operators must strictly follow the accompanying documents, especially safety and warning notices. With relevant training and experience, qualified personnel can identify potential risks and avoid hazards.

Reliable Grounding and Connection

During operation, the protective earth terminal (PE/M) must be reliably grounded. Improper grounding or connection may cause malfunction, data loss, or injury. Always follow the wiring requirements in this specification and periodically check connection reliability.

Disclaimer

We assume no liability for loss or error arising from use of this document. Consistency with actual hardware and software has been checked, but deviations may exist; complete consistency is not guaranteed. All data tested per regulations. We reserve the right to improve and correct function and performance descriptions in later versions. Watch for document updates.

Revision History

Revision	Date	Description
V1.0	August 2025	First release
V2.0	May 2026	Software upgrade

Scope of Document

This document applies to Zongheng Intelligent Control EG Series products, mainly including:

- Communication Coupler: EG8200Lite

Specific configuration subject to product model and order number.

Recycling and Disposal

To ensure environmentally compliant recycling, do not dispose of waste equipment with household waste. Contact a certified e-waste disposal service or follow local regulations. Recycle modules containing batteries (e.g., RTC batteries) separately.

产品介绍 PRODUCT INTRODUCTION



- [High Cost-Effectiveness](#)
- [4G Cat.1](#)
- [Remote O&M](#)
- [Store-and-Forward](#)
- [Visual Programming](#)
- [JavaScript Custom Development](#)

The EG Series is an edge computing gateway from Zongheng Intelligent Control. With **rich hardware interfaces**, **drag-and-drop programming**, a **"zero-code" design philosophy**, and **convenient remote management**, it responds to diverse IoT needs **rapidly, flexibly, accurately**, and **efficiently**.

The EG Series abstracts complex hardware interfaces and industrial network protocols into "nodes." Users can **flexibly use these nodes** by dragging and connecting them, **replacing traditional complex and inefficient coding processes**. This enables customers to focus on business logic and quickly build their own gateway devices. The mission of the EG Series is to continuously develop new nodes to serve industry customers and **adapt to the fragmented demands of the IoT industry**.

产品规格 PRODUCT SPECIFICATION

Model		EG8200Lite
Core Configuration	Processor	A7 @ 1.2 GHz
	RAM	256 MB
	Storage	4 G
4G (Optional)	Module	Quectel Cat.1 (4G)
	Frequency Bands	LTE-FDD: B1/B3/B5/B8 LTE-TDD: B34/B38/B39/B40/B41
	Transmit Power	LTE-FDD: Class 3 (23 dBm ±2 dB) LTE-TDD: Class 3 (23 dBm ±2 dB)
	Bandwidth (theoretical max.)	LTE-FDD: DL ≤10 Mbps, UL ≤5 Mbps LTE-TDD: DL ≤8.96 Mbps, UL ≤3.1 Mbps
Ethernet	WAN/LAN	1 × 10/100 Mbps auto-negotiation
RS485	Ports	2
	Terminal	A, B
	Baud Rate	2400 – 921600 bps
	Data Bits	7, 8
	Stop Bits	1, 2
	Parity	NONE, EVEN, ODD
	Protection	ESD, surge protection
Electrical	Certification	CE
	Adapter	12 V / 1 A
	Operating Voltage	9 – 36 V
	Operating Current	60 mA @ 12 V

产品规格 PRODUCT SPECIFICATION

Environmental	Operating Temperature	-20 to 85 °C
	Storage Temperature	-20 to 85 °C
	Operating Humidity	0 – 95% RH (non-condensing)
	Storage Humidity	0 – 95% RH (non-condensing)
Mechanical	Dimensions	83.8 × 58.5 × 25 mm
	Enclosure Material	Galvanized steel
	Mounting	DIN rail
	Cooling	Passive
	Reset Button	Press 10 s to reset
EMC	ESD	Air: Level 3 ±8 kV Contact: Level 2 ±4 kV
	Surge	Level 2 ±1 kV
	EFT	Level 2 ±1 kV
Software Features	Remote O&M	√
	Remote Management	√
	Remote Upgrade	√
	Virtual Network Port	√
	Virtual Serial Port	√
	Visual Programming	√
	Industry Protocols	CJ188 / DLT645 / HJ212 / Modbus / OPC UA* / BACnet* / ...
	Network Protocols	MQTT / HTTP / TCP / UDP / WebSocket / Alibaba Cloud IoT Platform / OneNET / ...

*EG8200Lite requires downloading third-party nodes.

产品总览 PRODUCT OVERVIEW



EG8200Lite Front View



EG8200Lite Rear View

产品总览 PRODUCT OVERVIEW



EG8200Lite Top View



EG8200Lite Bottom View

接线说明 WIRING INSTRUCTION

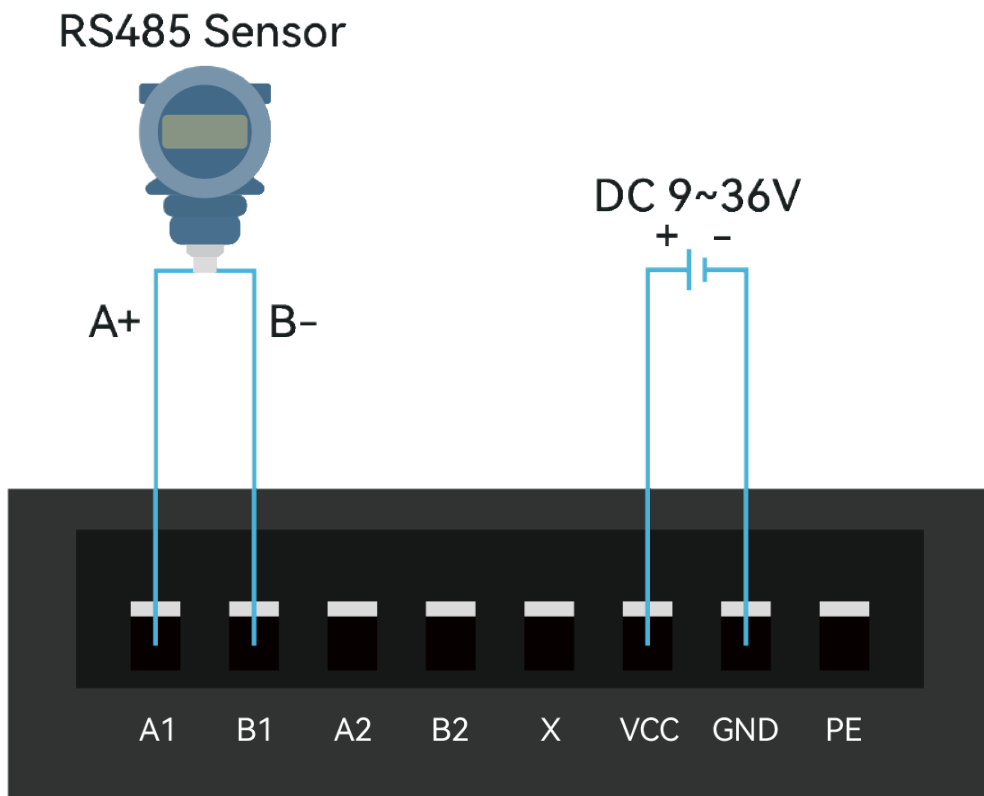

Power & RS485 Wiring Diagram

安装说明 INSTALLATION INSTRUCTION



Product Dimensions

A LEADING PROVIDER OF INTEGRATED IT AND OT PRODUCTS

R&D Center :

CHENGDU IOTRouter TECHNOLOGY CO., LTD
No. 599, Section 1, Huafu Avenue, Shuangliu District,
Chengdu city, Sichuan Province, China

Website :

en.iotrouter.com

Mail :

agneswang@iotrouter.com
queeney@iotrouter.com



WA: agneswang



WA: queeney